

Assembly Manual

YORK T900 PLUS

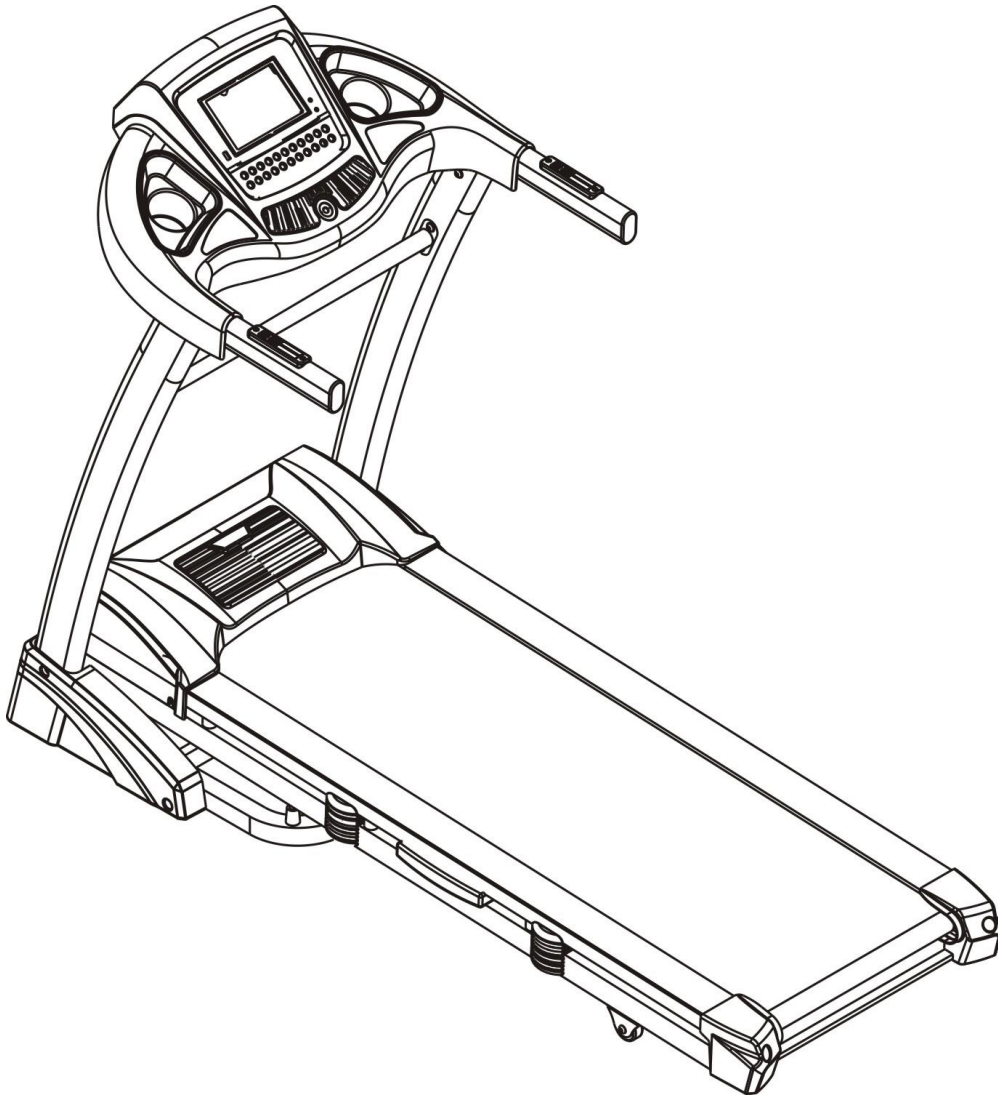

Please read all precautions and instructions in this manual in detail before using this equipment. Save this manual for future reference.

CONTENTS

Contents	1
Safety Caution	2-3
Assembly Instruction	4-7
Operation Guide	7-12
How to Fold and Move	13
Suggested Stretches	14-15
Maintenance	16-17
Exploded Drawing	18
Part List	19

When using this product, basic precautions should always be followed, including the following:

Please read the instruction carefully before starting to use this product.

Danger – To reduce the risk of electric shock:

1. Always unplug this product from the electrical outlet immediately after using and before cleaning.

Warning – To reduce the risk of burns, fire, electric shock, or physical injury:

1. The product should never be left unattended while plugged in. Unplug the product from the outlet when not in use.
2. Minors must be accompanied by the adults when using the treadmill & keep small children away from treadmill during operation.
3. Be sure to use the product only for its intended use as described in this manual. Do not use any attachment not recommended by the manufacturer in order to avoid any danger or accidents.
4. Never operate the product if it has a damaged cord or plug, if it is not working properly, if it has been damaged, or dropped into water. Please call service center of seller for examination and repair.
5. Do not carry this product by the supply cord or use the cord as a handle.
6. Keep the cord away from hot surfaces or ground.
7. Never operate the product with the air vents blocked. Keep the air vents free of lint, hair, etc.
8. Never drop or insert any objects into any openings.
9. This equipment is designed for indoor use only, do not use or operate outdoors.
10. Do not operate where aerosol (spray) products are being used or where oxygen is thin.
11. Before turning the product power off, turn all controls to the off position then remove the plug from the outlet.
12. Connect the product to a properly grounded outlet only.
13. Your product is intended for use in cool, dry conditions. You should avoid storage in extreme cold, hot or damp areas as this may lead to corrosion and other related problems. Allowed temperature is from 5 to 40 degrees.
14. Keep a safety distance of 2000mm x 1000 mm away from the treadmill.
15. This machine is only intended for household use.
16. Stop using the treadmill if you feel faint, dizzy, or short of breath.
17. Wear appropriate exercise clothes when using the treadmill. Do not wear loose clothes that can get caught in the treadmill. Athletic support clothes are recommended, always wear athletic shoes & never run on the treadmill with bare feet, wearing only stockings or in slippers or sandals.

GROUNDING INSTRUCTIONS

The products must be grounded first. If malfunction or breakdown occurs, grounding will provide a path of least resistance for electric current to reduce the risk of electric shock.

The product is equipped with a cord having an equipment-grounding conductor and a grounding plug.

The plug must be plugged into an appropriate outlet that is properly installed and grounded in accordance with all local codes and ordinances.

Danger – Improper connection of the equipment-grounding conductor can result in a risk of electric shock. Check with a qualified electrician or serviceman if you are in doubt as to whether the products are properly grounded. Do not modify the plug provided with the product – if it will not fit the outlet, have a proper outlet installed by a qualified electrician.

The product is for use on 220-240 volt and has a grounding plug that looks like the plug illustrated in the figure. Make sure that the product is connected to an outlet having the same configuration as the plug.

There is no need to use any adapter for this product.

Figure
Grounding methods

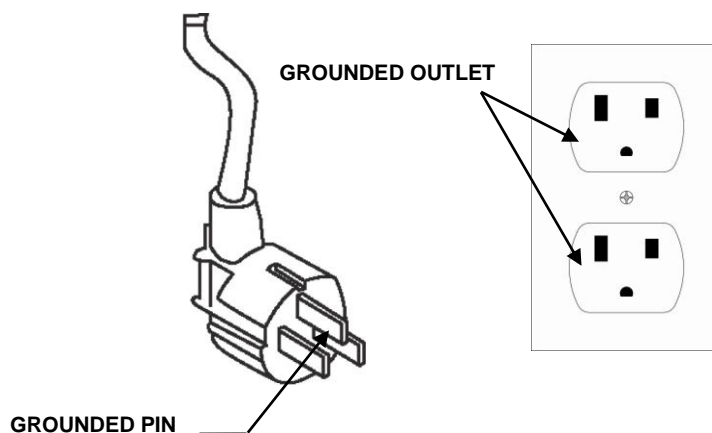

ASSEMBLY INSTRUCTIONS

PARTS SUPPLIED AS BELOW:

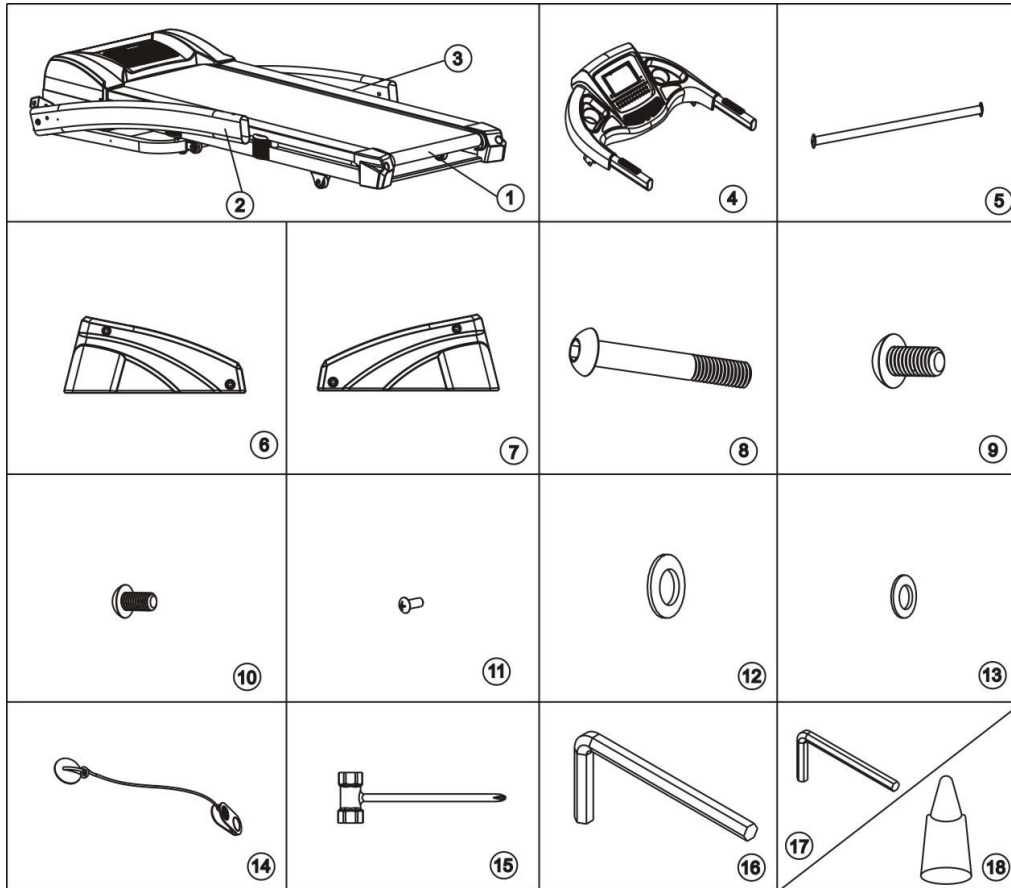

Part list					
No.	Description	Quantity	No.	Description	Quantity
1	Main frame	1 set	10	Bolt M8x15	4 pcs
2	Left upright	1 pc	11	Bolt M5x12	4 pcs
3	Right upright	1 pc	12	Washer M10	4 pcs
4	Console	1 pc	13	Washer M8	4 pcs
5	Connecting tube	1 pc	14	Safety key	1 pc
6	Left base cover	1 pc	15	Screwdriver	1 pc
7	Right base cover	1 pc	16	Wrench 6#	1 pc
8	Bolt M10x50	2 pcs	17	Wrench 5#	1 pc
9	Bolt M10x20	2 pcs	18	Lubricant oil	1 pc

ASSEMBLY INSTRUCTIONS

STEP 1

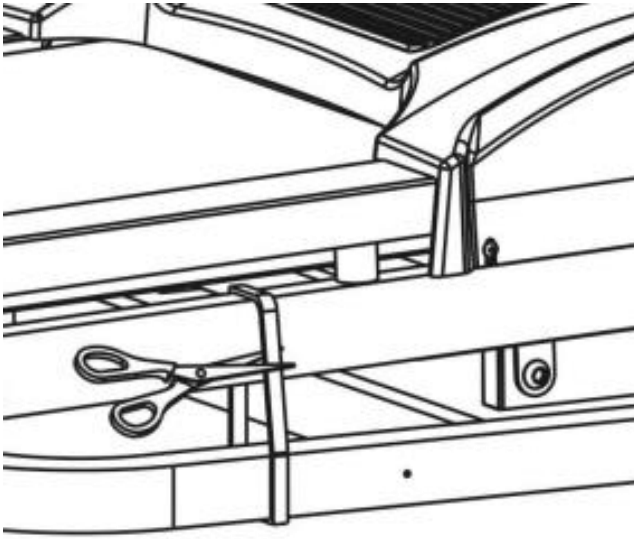

1. Please note that this treadmill needs at least two people to complete assembly.
2. Open the carton box, and take out all the protection foam and assembly parts.
3. As the photo shows, take out the running deck from the box, lay it on the flat floor, and then to cut the belt.

! DANGER!

Do not cut the belt before moving it out from carton, failure to do so could result in body injury.

STEP 2

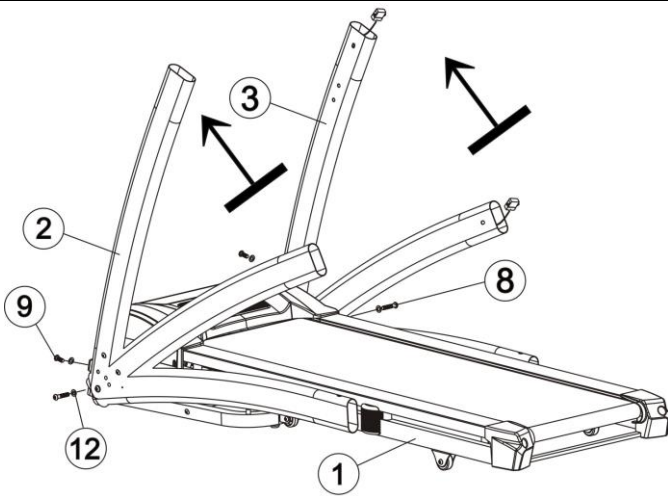

1. Lift up the left upright (2) and use the 6# wrench (16) to fasten the left upright (2) with 1 pc M10x50 bolt (8), 1 pc M10x20 bolt, (9) and 1 pcs M10 washers (12). Do the same for the right upright (3).

2. Do not tightly fasten all the bolts and screws at this step.

STEP 3

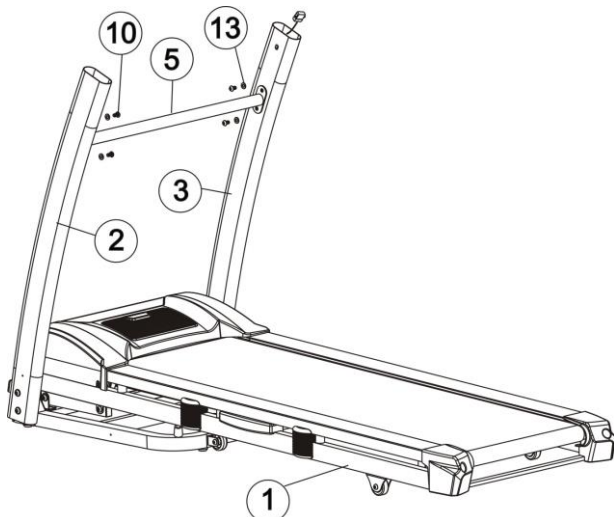

1. Use 5# wrench (17) to fasten connecting tube (5) to the left upright (2) and the right upright (3) with each 2 pcs M8*15 bolt (10) and 2 pcs M8 washer (13)

2. Do not tightly fasten all the bolts and screws at this step.

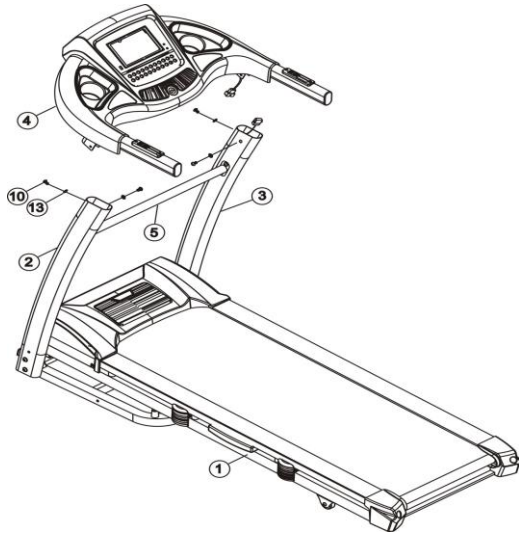
ASSEMBLY INSTRUCTIONS**STEP 4**

1. Connect the cable extent from console (4) with the cable extent from right upright (3). Pay attention to the connection of the cable, a wrong connection or rough operation would cause damage of the connector.

2. Use the 5# wrench (17) to fasten the console (4) to the left upright (2) and the right upright (3) with each 2 pcs M8*15 bolts (10) and 2pcs M8 washers (13)

3. Tightly fasten all the bolts and screws at step 2, step 3 and step 4.

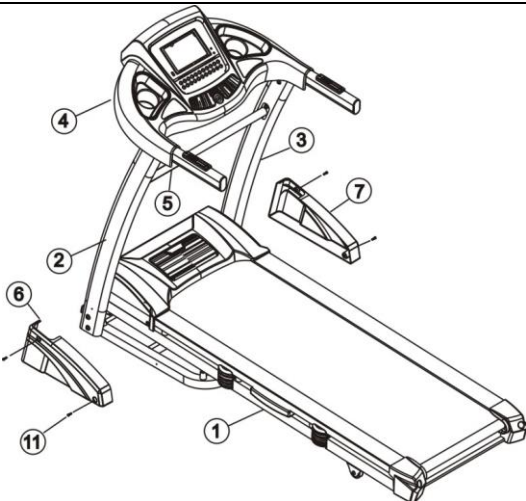

Use the screwdriver (15) to install the left base cover (6) to the left upright (2) with 2 pcs M5x12 bolts (11). Do the same for right base cover (7).

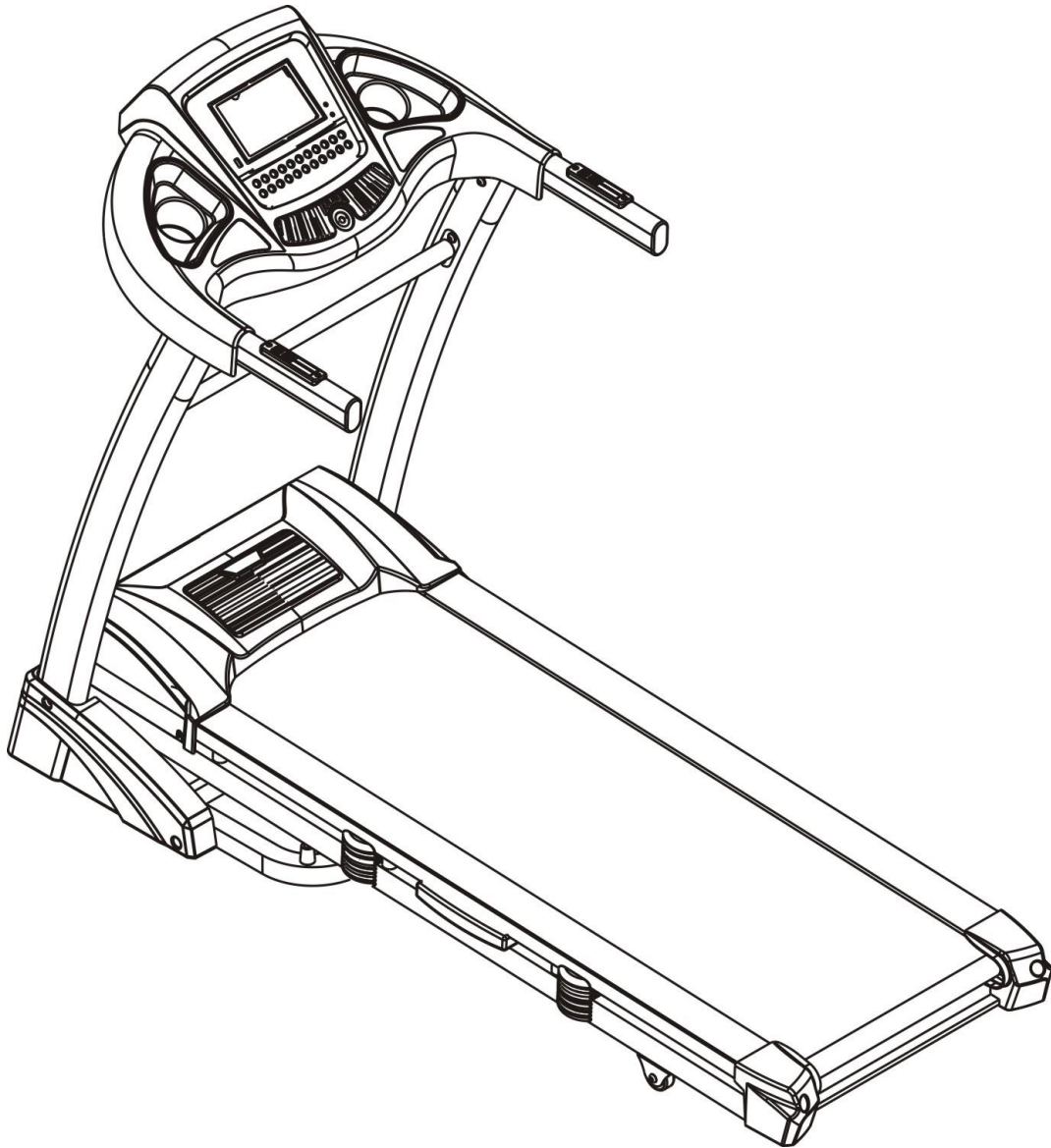
ASSEMBLY INSTRUCTIONS

NOTE: For your safety and comfort, please check if all screws are fastened.

GENERAL SAFETY TIPS

- A.** Practice mounting and dismounting your treadmill before beginning your workout.
- B.** Attach the safety key to the computer (the treadmill will not operate without the Safety Key). Clip the other end of the safety key to your clothing before exercising to ensure the treadmill will stop if the user accidentally walks off the Treadmill.
- C.** If the user falls off the treadmill, the safety key will come off the computer and the treadmill will stop at once to avoid further injury.
- D.** Do not stand on the walking belt while starting the treadmill. Straddle the belt and stand on the plastic foot rails.
- E.** The treadmill will start at 1.0KM/H after countdown. If you are a new user, stay at a slow speed and hold onto the hand grips until you become comfortable.

QUICK REFERENCE GUIDE



DISPLAY FUNCTION

- TIME:** Accumulates total workout time from 0:00 to 99:00 minutes.
- PULSE:** When pulse signal is detected by grasping both stainless steel pick-ups on front handrails, it will display your current heart rate in beats per minute from 50 to 200.
- INCLINE:** Displays the current deck incline from starting at level 1 to 15.
- SPEED:** Displays the current belt speed from starting at 1.0Km/h to 20.0Km/h.
- CALORIE:** Accumulates calorie consumption during exercise. Max. Value is 990 KCAL.
- DISTANCE:** Accumulates total workout distance from 0.0 to 99.0 kilometers by count-up.

OPERATION GUIDE

GETTING STARTED

NOTES:

1. Check to make sure nothing is on or will hinder the movement of the treadmill.
2. Plug in the power cord and turn the treadmill ON.
3. Stand on the foot rails of the treadmill.
4. Attach the safety key clip to part of your clothing.
5. Put the safety key into the safety key hole in the console, and then the treadmill will be on start/ready status.
6. There are two buttons on both handrail, right is SPEED+ and SPEED-, left is INCLINE+ and INCLINE-, and it will perform same functions as SPEED +/- and INCLINE +/- buttons on the computer.
7. During your workout in any mode, when you press the STOP button, the treadmill will be paused, if you want to resume your workout, you can press START button and all previous data will resume counting, the treadmill belt will begin moving after count-down. If you want to go to start/ready status, press STOP button again after pausing the treadmill. During selecting program or setting information, pressing the STOP button will return to start/ready status.
8. You have two options to start your workout:

A. QUICK START

Simply press the START button to begin working out.

B. SELECT A PROGRAM

Select a manual program by pressing the MODE or PROGRAM button to enter a manual program, or one of 8 training goals.

QUICK-START OPERATION

STEP 1: Attach the Safety key to wake display up; the treadmill then will be on start/ready status.

STEP 2: Press the START button to begin belt movement after a 5 second count-down. Use the SPEED +/- or QUICK SPEED buttons to adjust the desired speed at any time during training; use the INCLINE +/- or QUICK INCLINE buttons to adjust the incline at any time during training. The speed and incline can also be adjusted by the buttons on handrail, the buttons on left handrail to adjust incline, the buttons on right handrail to adjust speed.

STEP 3: To get a pulse reading, simply hold stainless steel pick-ups on handrails. It may take a few seconds for the display to reach the actual number. The pulse rate will be displayed on PULSE window.

STEP 4: Press STOP button to stop your workout or pull safety key away from its position to shut down the computer. Press STOP button will pause the program, if you want to resume your workout, you can press START button and all previous data will resume counting, treadmill belt will begin movement after count-down. If you want to go to start/ready status, press STOP button again after pausing the treadmill.

STEP 5: During quick-start operation, TIME, CALORIE and DISTANCE will count up.

MANUAL PROGRAMS OPERATION

NOTES: Under this program, one of **DISTANCE**, **CALORIE** and **TIME** can be set to count-down for your workout, the others will count up during your workout. After the count-down reaches zero, the program will be ended and stop the belt movement. If you need to continue, press the **START** button to begin belt movement after the count-down.

STEP 1: Attach the safety key to wake display up; the treadmill then will be on start/ready status.

STEP 2: Press **MODE** button, the **TIME** window will display 30:00, press **SPEED +/-** button to set count-down **TIME** from 5:00 minutes to 99:00 minutes.

If you do not like to set **TIME** for count-down and pass to others, press **MODE** again, the **DIST** window will display 1.0, you can set count-down **DISTANCE** from 1.0KM - 99.0KM. If you do not like to set **DISTANCE** for count-down and pass to others, press **MODE** again, the **CAL.** window will display 50, you can set count-down **CALORIE** from 20 CAL to 990 CAL.

STEP 3: After finishing setting count-down for your workout, press **START** to begin belt movement after count-down.

STEP 4: During the program you can adjust the speed and incline by pressing **SPEED +/-** and **INCLINE +/-** buttons, or **QUICK SPEED** and **QUICK INCLINE** buttons to jump directly to a setting. The speed and incline can also be adjusted by the buttons on handrail, the buttons on left handrail to adjust incline, the buttons on right handrail to adjust speed.

STEP 5: Press **STOP** button to stop your workout or pull safety key away from its position to shut down the computer.

PRESET PROGRAMS OPERATION

NOTES:

All the preset programs are made up with 18 time-based segments; the speed and incline are preset on each segment. The elapse time of 18 segments on each program will be automatically arranged according to the time you set for your workout time. There are 64 preset programs for 8 different training goals, and 8 different intensity levels on each training goals.

STEP 1: Attach the safety key to wake display up; the treadmill then will be on start/ready status.

STEP 2: Press **PROGRAM** button to scroll through the 8-preset program, and **BODY FAT** function. A program will be selected once you press the **PROGRAM** button. After selecting a training goal, press **MODE** button to select an intensity from L1 to L8. After selecting an intensity, then press **SPEED +/-** buttons to modify the elapsing time. The pre-set elapsing time of each program is 30:00 minutes, and it can be set from 5:00 to 99:00 minutes.

STEP 3: After modifying the elapsing time, press **START** button to accept and begin your workout.

OPERATION GUIDE

STEP 4: During the program you can adjust the SPEED & INCLINE by pressing SPEED +/- and INCLINE +/- buttons, or use QUICK SPEED and QUICK INCLINE buttons to jump directly to a setting. The speed and incline can also be adjusted by the buttons on both handrails, the buttons on left handrail to adjust incline, the buttons on right handrail to adjust speed. However, the SPEED and INCLINE you adjust will only be effective on the ongoing segment, after the segment finished, the SPEED and INCLINE will continue with preset values.

STEP 5: Press the STOP button to stop your workout or pull safety key away from its position to shut down the computer.

USING THE PULSE FUNCTION

The PULSE Window on your computer works in conjunction with the pulse sensors on both handrails. When you are ready to read your pulse:

1. Place both hands firmly on the pulse sensors. For the most accurate reading, it is important to use both hands.
2. Your estimated heart rate will display in the PULSE window approximately 5 seconds after you hold the pulse sensors.
3. This estimate is not exact and persons with medical conditions and/or a specific need for accurate heart rate monitoring should not rely on the estimations provided.

USING THE AUDIO FUNCTION

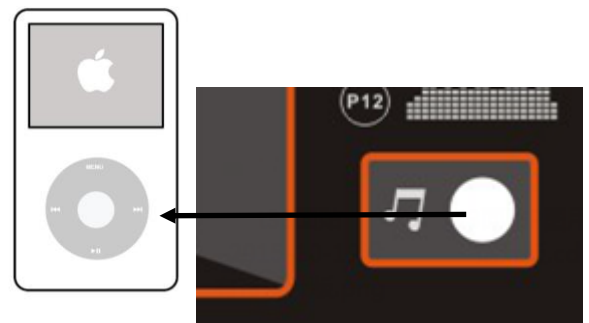

As the figure shows, plug one end of the audio cable to the audio jack on computer, and then plug the other end of the audio cable to MP3 player. The speaker on the computer will then play the music from MP3 player. The volume of speaker can only be adjusted by MP3 player.





BUILD-IN MP3 PLAYER

The computer has a built-in MP3 player function, it can be operated with the following instruction:

Turn on the power of treadmill, attach the Safety key to wake display up, and then plug-in USB flash or SD card.

Press  button will decrease the voice of speaker. Press  button will

increase the voice of speaker. Press  button play next music, Press  button to play previous music, press this button down.

BODY FAT SCALE

This function is to estimate your body fat according to the basic information of your body condition.

This estimate is not exact and persons with medical conditions and/or a specific need for accurate body fat value should not rely on the estimations provided.

STEP 2: Press PROGRAM button repeatedly, on the “9” time pressing PROGRAM button, the DISTANCE window will display FAT. Press MODE button to set the relative parameters: AGE, GENDER, HEIGHT, and WEIGHT.

STEP 3: After entering BODY FAT function by pressing MODE button, the SPEED window display F1, the INCLINE window will display 25, it represents AGE, press SPEED +/- button to set age from 10-99. Then press MODE button to go to next step.

STEP 4: After pressing MODE button, the SPEED window will display F2, the INCLINE window will display 01, it represents GENDER, press SPEED +/- button to set gender from 01 -02, 01 represents MALE, 02 represents FEMALE. Then press MODE button to go to next step.

STEP 5: After pressing MODE button, the SPEED window will display F3, the INCLINE window will display 170, it represents HEIGHT, press SPEED +/- button to set height from 100CM-199CM. Then press MODE button to go to next step.

STEP 6: After pressing MODE button, the SPEED window will display F4, the INCLINE window will display 70, it represents WEIGHT, press SPEED +/- button to set weight from 20KG-150KG. Then press MODE button to go to next step.

STEP 7: After finished setting all the necessary information of your body condition, press MODE button again, the SPEED window will then display F5, the INCLINE window will display “--”, it means the computer will start to work on calculating, then hold the pulse sensor on handrail with both of your hands, around 8 seconds after, the body fat result will be displayed on INCLINE window.

BODY FAT CHART

The result that given by body fat scale can be a reference of body condition, check your body condition according to the left chart with the result you get from the treadmill.

Body condition	Result
Obese	BMI > 30
Overweight	26 < BMI < 30
Fit	19 < BMI < 25
Underweight	BMI < 19

HOW TO FOLD AND MOVE

HOW TO FOLD THE TREADMILL

Before folding the treadmill ensure incline is set to zero, and unplug the power cord.

CAUTION: You must be able to safely lift 45 pounds (20kg) in order to raise, lower, or move the treadmill.

1. Hold the treadmill with your hands in the locations shown at the right. **CAUTION:** To decrease the possibility of injury, bend your legs and keep your back straight. As you raise the treadmill, make sure to lift with your legs rather than your back. Raise the treadmill until the running deck is firmly held by the folding pole as the right figure shows.

2. If you want to put the treadmill to the work position, firstly, pull the folding knob outward as figure shows, then lay down the running deck light onto floor.

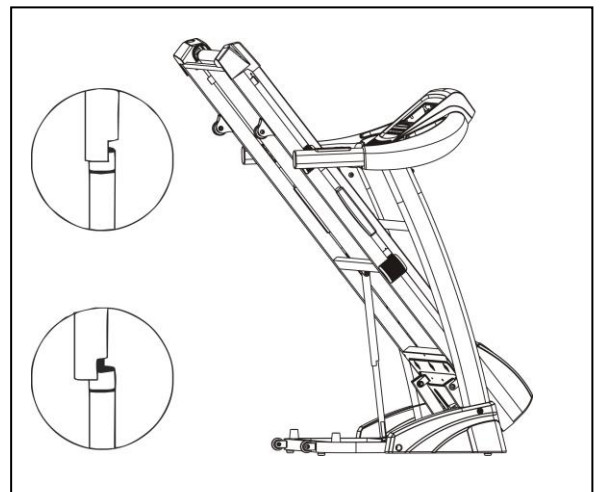
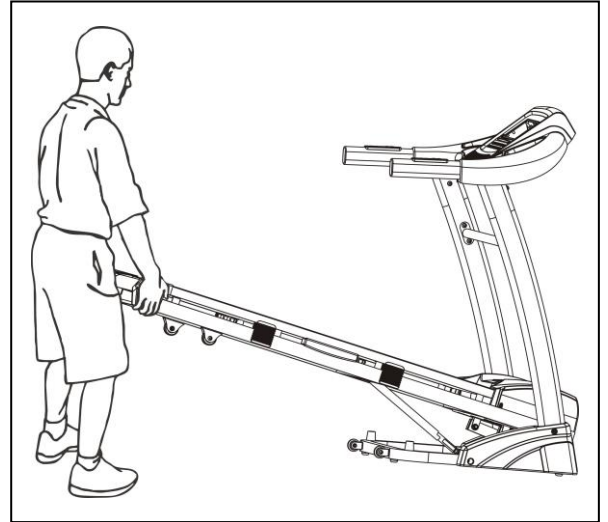

HOW TO MOVE THE TREADMILL

1. Hold the handrails as shown and place one foot against a wheel.
2. Tilt the treadmill back until it rolls freely on the wheels. Carefully move the treadmill to the desired location.

Never move the treadmill without tipping it back. To reduce the risk of injury, use extreme caution while moving the treadmill. Do not attempt to move the treadmill over an uneven surface.

3. Place one foot on a wheel, and carefully lower the treadmill until it is resting in the storage position.

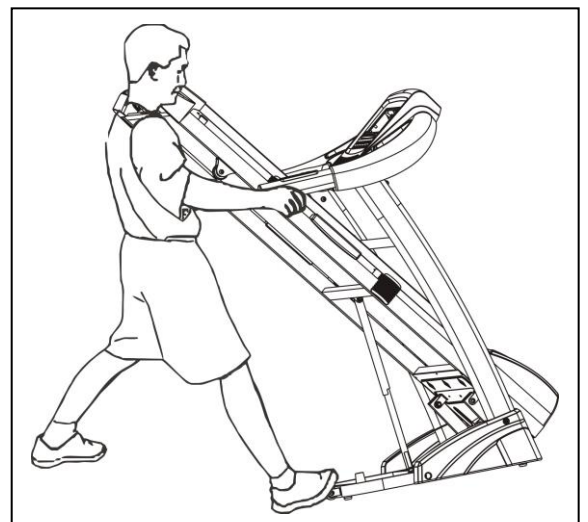

SUGGESTED STRETCHES

A successful exercise program consists of a warm-up, aerobic exercise, and a cool-down. Do the entire program at least two and preferably three times a week, resting for a day between workouts. After several months, you can increase your workouts to four or five times per week.

Warming up is an important part of your workout, and should begin every session. It prepares your body for more strenuous exercise by heating up and stretching out your muscles, increasing your circulation and pulse rate, and delivering more oxygen to your muscles. At the end of your workout, repeat these exercises to reduce sore muscle problems. We suggest the following warm-up and cool-down exercises:

1. Inner Thigh Stretch

Sit with the soles of your feet together with your knees pointing outward. Pull your feet as close into your groin as possible. Gently push your knees towards the floor. Hold for 15 counts.

**2. Hamstring Stretch**

Sit with your right leg extended. Rest the sole of your left foot against your right inner thigh. Stretch toward your toe as far as possible. Hold for 15 counts. Relax and then repeat with left leg extended.

**3. Head Roll**

Rotate your head to the right for one count, feeling the stretch up the left side of your neck. Next, rotate your head back for one count, stretching your chin to the ceiling and letting your mouth open. Rotate your head to the left for one count, and finally, drop your head to your chest for one count.



SUGGESTED STRETCHES**4. Shoulder Lift**

Lift your right shoulder up toward your ear for one count. Then lift your left shoulder up for one count as you lower your right shoulder.

**5. Toe Touch**

Slowly bend forward from your waist, letting your back and Shoulders relax as you stretch toward your toes.

Reach down as far as you can and hold for 15 counts.

**6. Calf-Achilles Stretch**

Lean against a wall with your left leg in front of the right and your arms forward. Keep your right leg straight and the left foot on the floor; then bend the left leg and lean forward by moving your hips toward the wall. Hold, and then repeat on the other side for 15 counts.

**7. Side Stretch**

Open your arms to the side and continue lifting them until they are over your head.

Reach your right arm as far upward toward

The ceiling as you can for one count.

Feel the stretch up your right side.

Repeat this action with your left arm.

WARNING! Before performing any maintenance to your treadmill, always unplug the power cord from the surge protector. To prevent electrical shock, be sure the power to the treadmill is OFF and the unit is unplugged from the wall electrical outlet before attempting any cleaning or maintenance.

CLEANING: Routine cleaning of your TREADMILL will extend the life of your treadmill.

AFTER EACH WORKOUT: Wipe off the console and other treadmill surfaces with a clean, water dampened soft cloth to remove excess perspiration. **USE NO CHEMICALS.**

WEEKLY: Use of a treadmill mat is recommended for ease of cleaning. Dirt from your shoes contacts the belt and eventually ends up underneath the treadmill. Vacuum underneath the treadmill once a week.

DECK LUBRICATION: The walking belt has been pre-lubricated at the factory. However, it is recommended that the walking board be checked periodically for lubrication to ensure optimal treadmill performance. Every 10 days or 10 hours of operation, lift the sides of the walking belt and feel the top surface of the walking board as far under as you can reach. If you feel signs of silicone, no further lubrication is required. If it feels dry to the touch, lubrication is needed. Ask your retailer or call Service line for the type of silicone.

TO APPLY LUBRICANT TO THE WALKING BOARD

- 1) Position the walking belt so that the seam is located on top and in the center of the walking board.
- 2) Lift up one side of the walking belt, reach under the belt about 10cm from the motor cover and as far into the centre of the walking board as possible squirt the lubrication onto the walking board in an S pattern moving from the front of treadmill to the rear.
- 3) Repeat application from the other side of the treadmill.
- 4) Start the treadmill and walk on the walking belt at approximately 2kph for several minutes to spread the lubrication evenly.

WARNING: Do not over-lubricate the walking board. Excess lubricant should be wiped off with a clean towel.

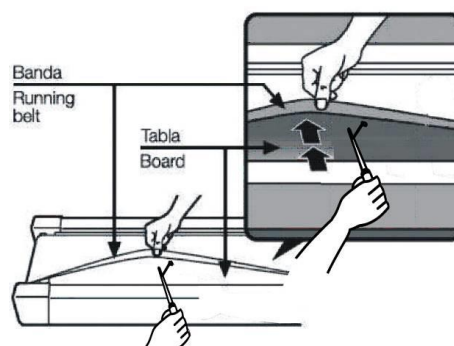

Running belt tension adjustment

The treadmill has been adjusted and passed QC inspection before leaving the factory. If there is phenomenon of bias running of the belt, the possible reasons might be:

- A. The frame is not stably laid
- B. The user is not running on the center of the running belt;
- C. The user's two feet are not using even strength.

For bias which cannot be fixed automatically, try the following methods to fix the belt, as picture shown

If the belt tends to move to the right, you should turn the belt adjustment screw on the right in clockwise direction **as shown in the picture A**. We recommend you turn 1/4 turn each time and check how it works. If the belt remains slanting to the right, then turn the belt adjustment screw on the left in counterclockwise direction 1/4 **turn**.

If the belt tends to move to the left, then turn the belt adjustment screw on the left in clockwise direction for 1/4 turn. If the belt remains slanting to the left, then turn the belt adjustment screw on the right in counterclockwise direction for 1/4 turn, as shown in the picture B

After having been used for a period, the belt might be slightly elongated, and slipping and halting might occur when a person is running on it. When this occurs, you should **turn** the screws on both sides with a 1/4 turn **clockwise**. If the belt is too tight, just loosen the screw on both sides for 1/4 turn **counterclockwise**, as shown in picture C.

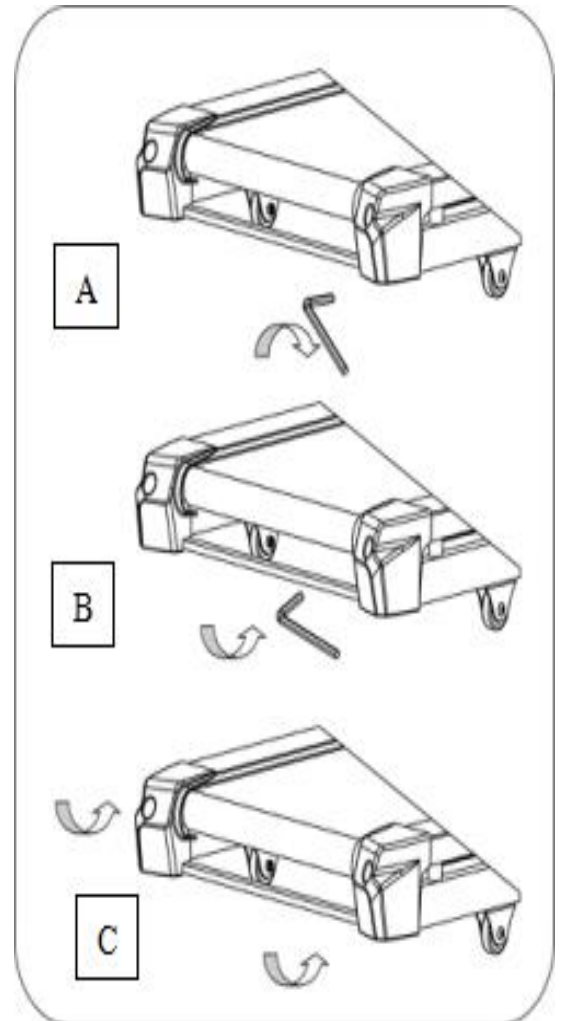

EXPLODED DRAWING

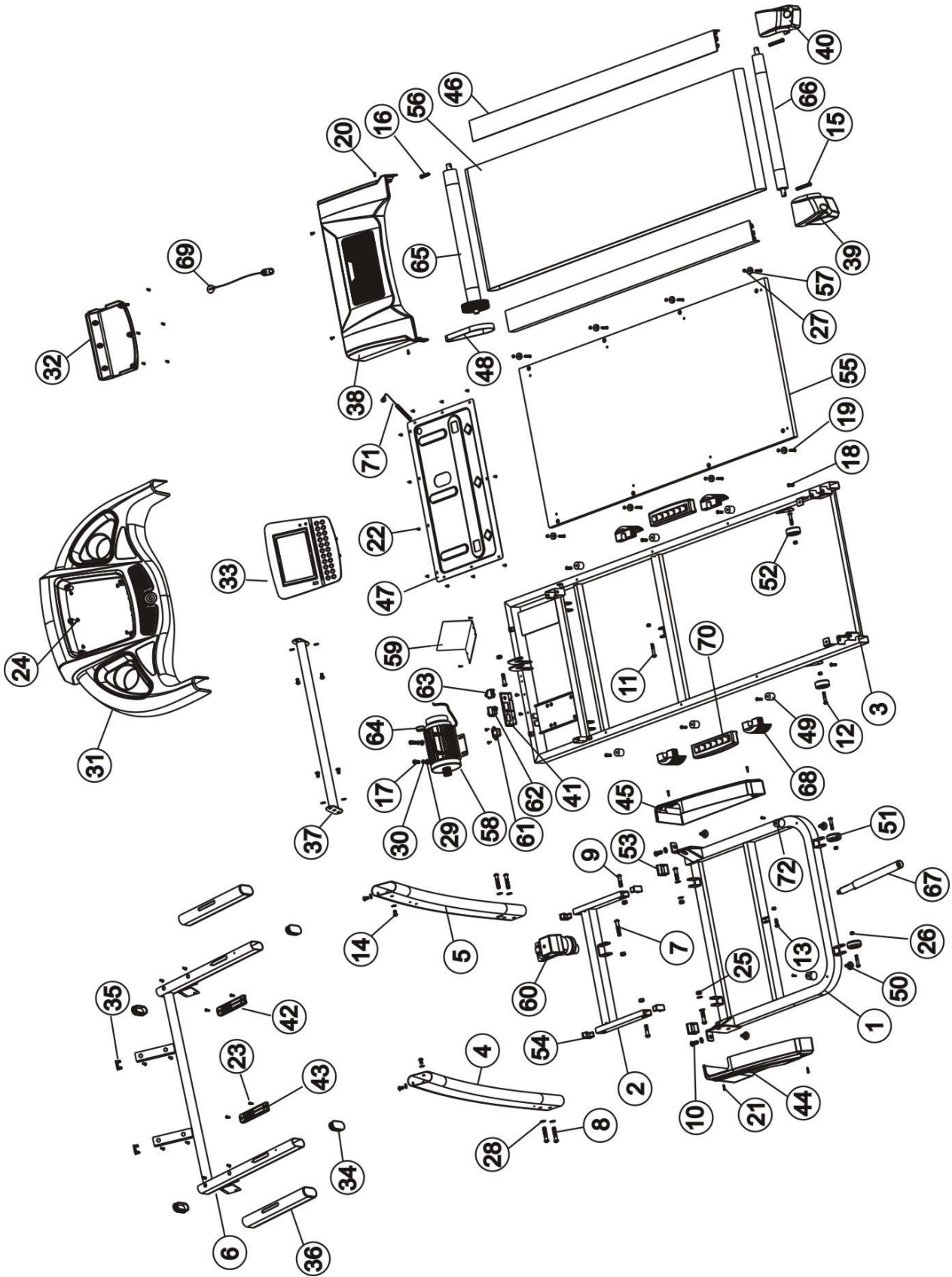

PART LIST

NO.	DESCRIPTION	Q'TY
1	BASE	1
2	INCLINE FRAME	1
3	MAIN FRAME	1
4	LEFT UPRIGHT	1
5	RIGHT UPRIGHT	1
6	CONSOLE RACK	1
7	BOLT M10*55	1
8	BOLT M10*50	4
9	BOLT M10*40	5
10	BOLT M10*20	2
11	BOLT M8*45	1
12	BOLT M8*40	4
13	BOLT M8*25	1
14	BOLT M8*15	8
15	BOLT M8*65	2
16	BOLT M8*55	1
17	BOLT M8*15	4
18	BOLT M6*25	8
19	SCREWS M5*28	8
20	SCREWS M5*10	6
21	SCREWS M5*12	4
22	SCREWS M4*12	24
23	SCREWS M4*15	4
24	SCREWS M4*10	19
25	CAP M10	6
26	CAP M8	6
27	NUT M5	8
28	WASHER M10	12
29	WASHER M8	8
30	SPRING WASHER M8	4
31	Console plastic housing upper	1
32	Console plastic housing bottom	1
33	Computer plastic	1
34	HANDRAIL END CAP 30*60	4
35	BASE CAP 15*30	2
36	HANDRAIL FOAM 30*60*300	2
37	REINFORCED TUBE	1

NO.	DESCRIPTION	Q'TY
38	MOTOR COVER	1
39	LEFT REAR END CAP	1
40	RIGHT REAR END CAP	1
41	POWER RACK	1
42	HANDRAIL BUTTON(L)	1
43	HANDRAIL BUTTON(R)	1
44	BASE COVER(L)	1
45	BASE COVER(R)	1
46	SIDE RAIL	2
47	BELLY PAN	1
48	V-BELT	1
49	CUSHION	6
50	BASE FOOT PAD	4
51	BASE WHEEL \varnothing 46*18* \varnothing 8.2	2
52	BASE WHEEL \varnothing 51*24* \varnothing 8.2	2
53	BASE CAP 38*38	2
54	BASE CAP 20*40	4
55	RUNNING DECK	1
56	RUNNING BELT	1
57	SIDE RAIL FASTENER	8
58	MOTOR	1
59	INVERTER	1
60	INCLINE MOTOR	1
61	POWER SWITCH	1
62	POWER CORD JACK	1
63	CIRCUIT BREAKER	1
64	MAGNETIC RING	1
65	FRONT ROLLER	1
66	REAR ROLLER	1
67	AIR CYLINDER	1
68	CUSHION	4
69	SAFETY KEY	1
70	AIR CUSHION	2
71	WAVED PIPE	1
72	FOOT PAD	2
73	BOLT M4*20	2